

**FICHE D'HOMOLOGATION /  
HOMOLOGATION FORM**

Homologation N°

**041-EM-51**



**COMMISSION  
INTERNATIONALE  
DE KARTING - FIA**



**MOTEUR / ENGINE  
MINI**

Constructeur / <i>Manufacturer</i>	TM Racing Spa
Marque / <i>Make</i>	<b>TM Racing</b>
Modèle / <i>Model</i>	<b>Mini 2</b>
Catégorie / <i>Categorie</i>	Group 3
Durée de l'homologation / <i>Validity of the Homologation</i>	2 ans / <i>2 years</i>
Nombre de pages / <i>Number of pages</i>	14
La présente Fiche d'Homologation reproduit descriptions, illustrations et dimensions du moteur au moment de l'homologation CIK-FIA.	<i>This Homologation Form reproduces descriptions, illustrations and dimensions of the engine at the moment of the CIK-FIA homologation.</i>
	
Photo du moteur complet côté pignon / <i>Photo of the complete engine drive side</i>	Photo du moteur complet côté opposé / <i>Photo of the complete engine opposite side</i>
Signature et tampon de l'ASN / <i>Signature and stamp of the ASN</i>	Signature et tampon de la CIK-FIA / <i>Signature and stamp of the CIK-FIA</i>
	

## INFORMATIONS TECHNIQUES / TECHNICAL INFORMATION

A

### Caractéristiques / Characteristics

Le nombre de décimales doit être de 2 ou en accord avec la tolérance appliquée. /  
The number of decimal places must be 2 or comply with the relevant tolerance.

Tolérances et remarques /  
Tolerances & remarks

<b>Cylindre / Cylinder</b>		
Volume du cylindre / <i>Cylinder volume</i>	59.85 cm <sup>3</sup>	< 60 cm <sup>3</sup>
Alésage d'origine / <i>Original bore</i>	41.89 mm	--
Alésage théorique maximum / <i>Maximum theoretical bore</i>	< 42.10 mm	
Course / <i>Stroke</i>	43.0 mm	±0.1 mm
<b>Vilebrequin / Crankshaft</b>		
Nombre de lumières d'admission / <i>Number of intake ports</i>	1	--
Largeur des lumières d'admission* / <i>Width of intake ports*</i>	26.0 mm	+0.1/-0.2 mm
Nombre de conduits/lumières de transfert, cylindre/carter / <i>Number of transfer ports/ducts, cylinder/sump</i>	2	--
Largeur des lumières de transfert* / <i>Width of transfer ports*</i>	25.4 mm	+0.4/-0.2 mm
Nombre de lumières d'échappement / <i>Number of exhaust ports</i>	1	--
Largeur des lumières d'échappement* / <i>Width of exhaust ports*</i>	28.0 mm	+0.1/-0.2 mm
Forme de la chambre de combustion / <i>Shape of combustion chamber</i>	Gabarit / <i>Template CIK</i>	
<b>Bielle / Conrod</b>		
Poids du vilebrequin complet, sans piston / <i>Weight of crankshaft complete, without piston</i>	1228 gr	±3 % total
Dimensions des paliers / <i>Dimensions of bearings</i>	20 x47 x 14	en/in mm
Type des paliers / <i>Type of bearings</i>	Roulement à billes / <i>Ball bearing</i>	
<b>Piston / Piston</b>		
Longueur (entre-axe) de la bielle / <i>Length between the axes of the conrod</i>	88.0 mm	±0.1 mm
Diamètre de la tête de bielle / <i>Diameter of big end</i>	24 mm	±0.05 mm
Diamètre du pied de bielle / <i>Diameter of small end</i>	16 mm	±0.05 mm
Poids de la bielle / <i>Weight of conrod</i>	53.1 gr	minimum
<b>Piston / Piston</b>		
Nombre de segments du piston / <i>Number of piston rings</i>	1	--
Poids du piston, segments du piston inclus / <i>Weight of the piston including piston rings</i>	58.6 gr	±10 % total
<b>Taille de l'axe de piston / Size of gudgeon pin</b>		
Taille de l'axe de piston / <i>Size of gudgeon pin</i>	35 x 12 mm	±0.8 mm
Poids de l'axe de piston / <i>Weight of gudgeon pin</i>	15.8 gr	±10 % total

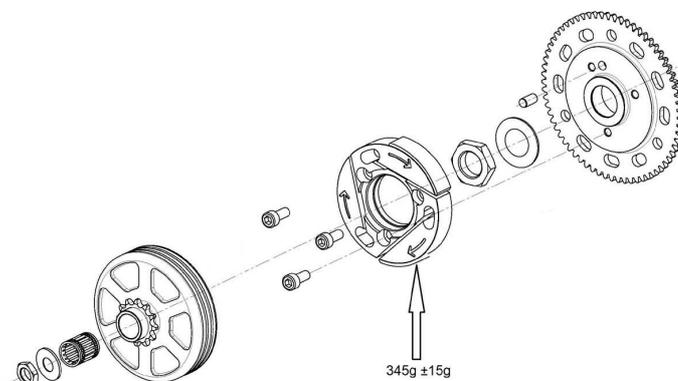
\* Toutes les dimensions peuvent être vérifiées à l'aide du gabarit du constructeur / All dimensions can be checked using the manufacturer's template

<b>B</b>	<b>Angles d'ouverture / Opening angles</b>		
	Lumière d'admission / Intake port	144.0°	+0 / -2°
	Lumière de transfert / Transfer port	114.5°	+0 / -2°
	Lumière d'échappement / Exhaust port	156.0°	+0 / -2°

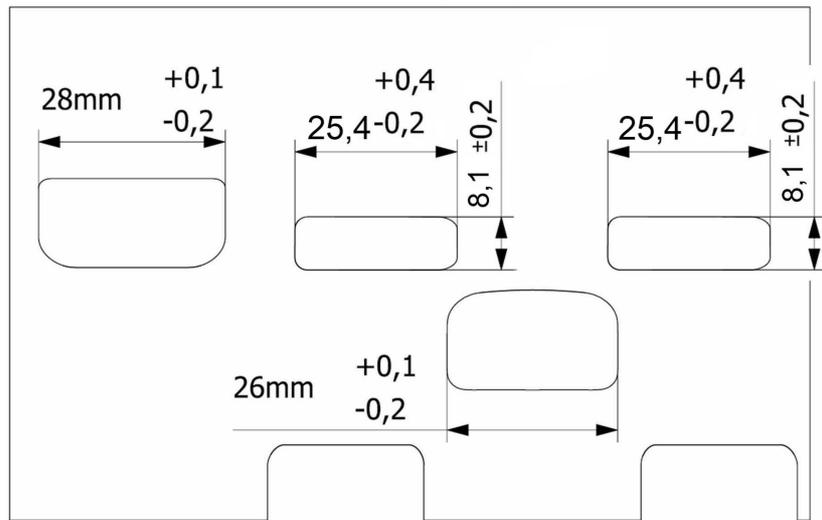
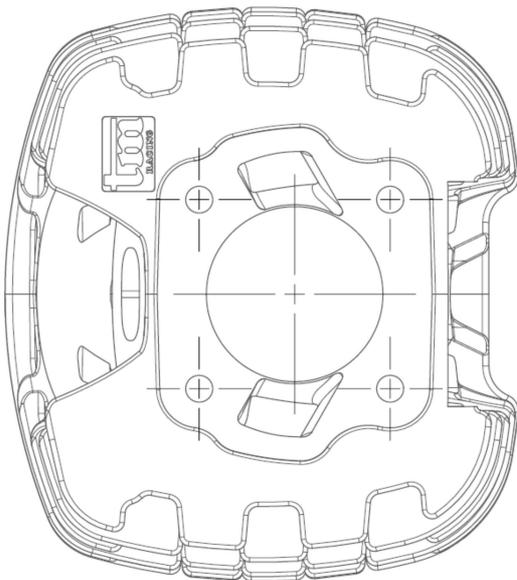
<b>C</b>	<b>Matériau / Material</b>	
	Culasse / Cylinder head	Aluminium-silicon alloy
	Cylindre / Cylinder	Aluminium-silicon alloy
	Carter / Sump	Aluminium-silicon alloy
	Vilebrequin / Crankshaft	Nickel chromium molybdenum alloy
	Bielle / Connecting rod	Nickel chromium molybdenum alloy
	Piston / Piston	Aluminium alloy

<b>D</b>	<b>Embrayage / Clutch</b>		
	Poids de l'embrayage assemblé / Weight of the clutch assembly	800 gr	minimum
	Dimensions de l'embrayage / Dimensions of the clutch	selon dessin technique n°26 / according to technical drawing no. 26	
	Poids de l'embrayage / Weight of the clutch	345 gr	±15 gr
	Diamètre interne de la cloche d'embrayage / Internal diameter of clutch bell	85.00 mm	maximum

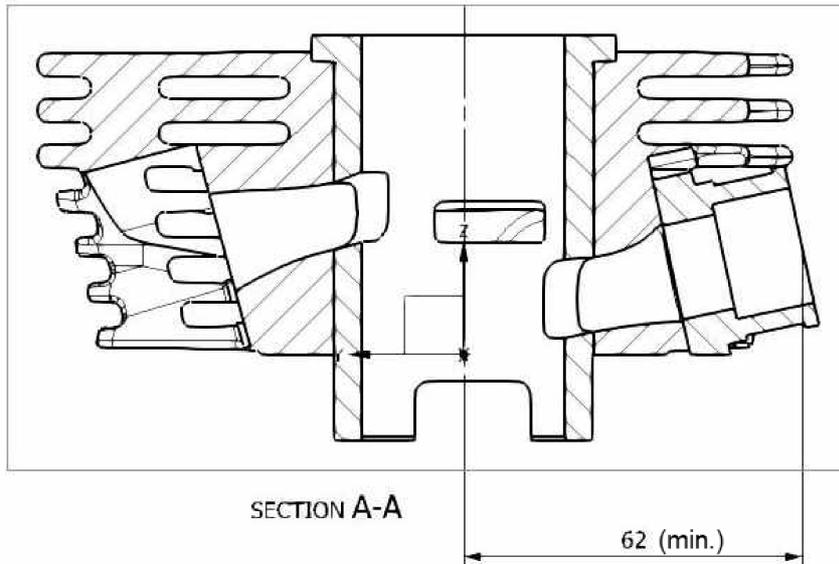
**Dessin de l'embrayage assemblé / Drawing of the clutch assembly**



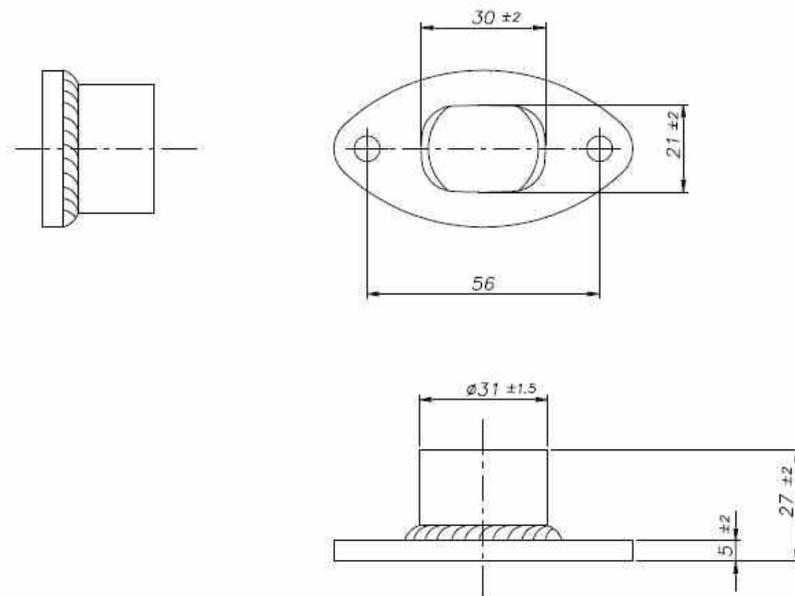
E

Photos, dessins et graphiques / *Photos, drawings and graphs*1. Cylindre / *Cylinder*Dessin du développement du cylindre (avec dimensions) /  
*Drawing of the cylinder development (with dimensions)*Dessin du pied du cylindre /  
*Drawing of the cylinder base*Photo du pied du cylindre / *Photo of the cylinder base*

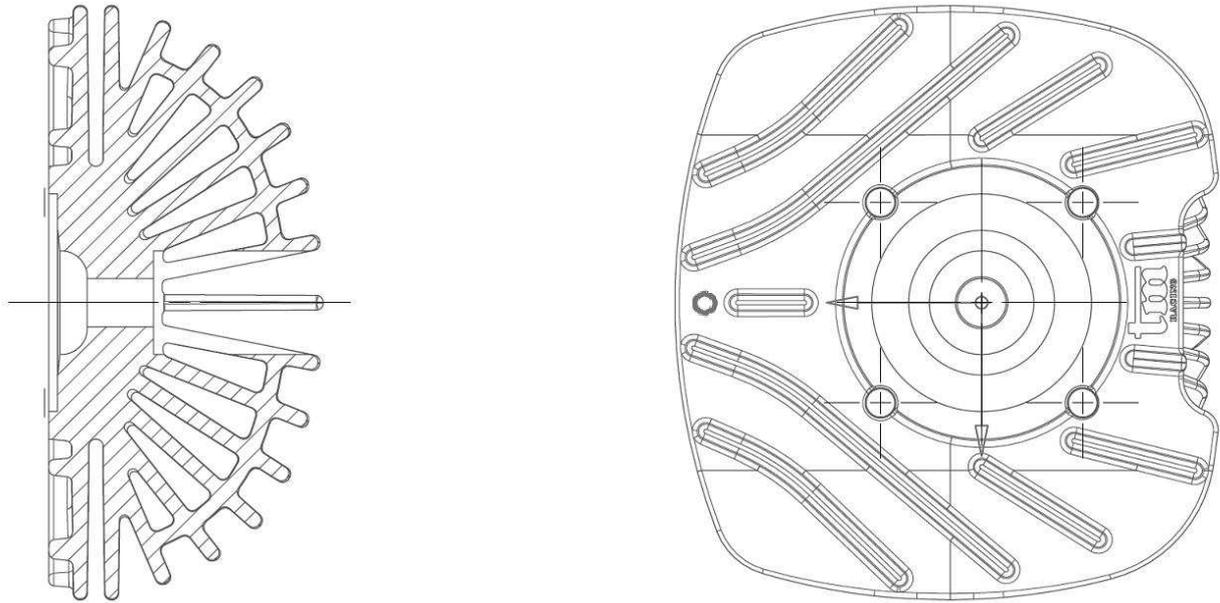
**Vue en coupe verticale du cylindre complet**  
**(avec distance minimale de la surface d'appui du carburateur par rapport à l'axe du cylindre) /**  
**Vertical cross section view of the complete cylinder**  
**(with minimum distance of the carburettor support surface to cylinder axis)**



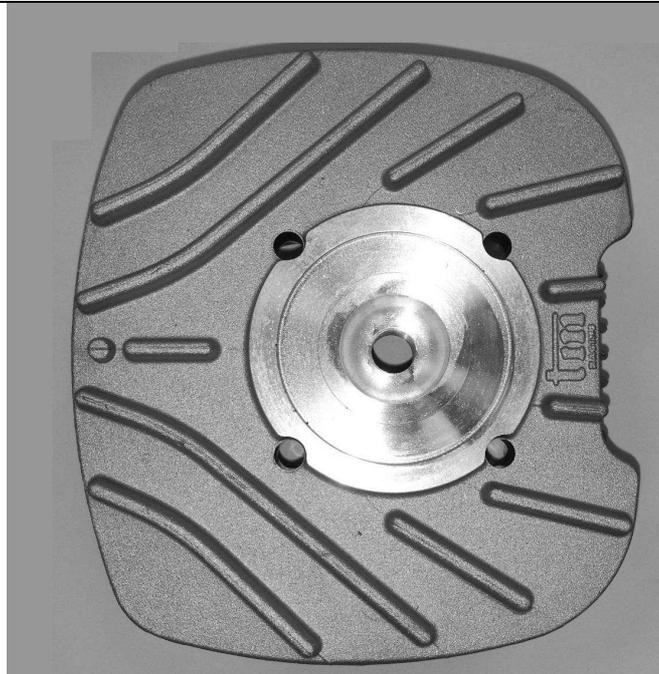
**Dessin du collecteur d'échappement (dimensions principales avec tolérances) /**  
**Drawing of exhaust manifold (main dimensions with tolerances)**



**Dessin de la culasse et de la chambre de combustion (sans dimensions) /  
Drawing of the cylinder head and the combustion chamber (without dimensions)**

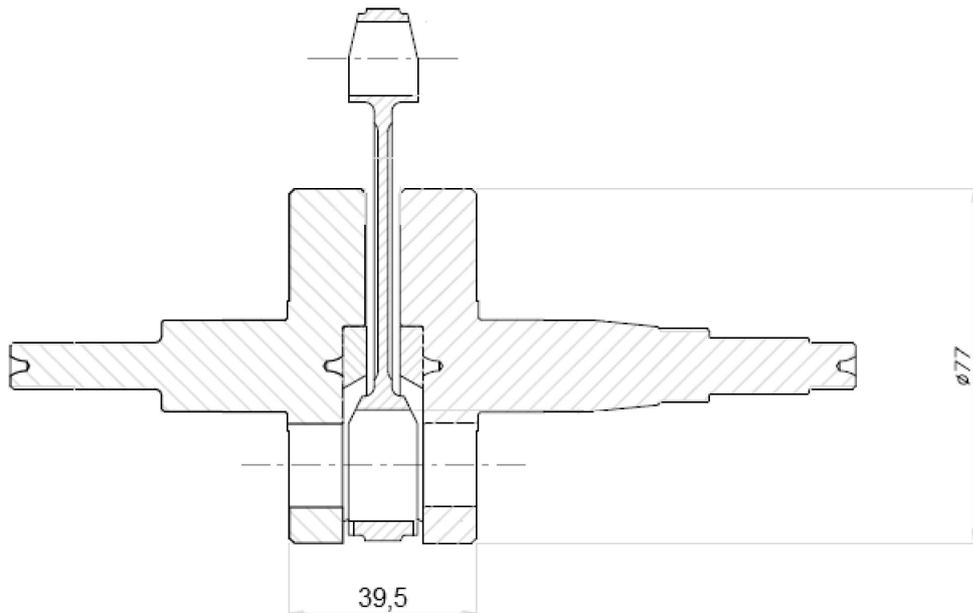


**Photo de la culasse et de la chambre de combustion /  
Photo of the cylinder head and the combustion chamber**



**2. Vilebrequin, bielle, piston et carter /  
Crankshaft, conrod, piston and crankcase**

**Dessin du vilebrequin complet (dimensions sans tolérances) /  
Drawing of the complete crankshaft (dimensions without tolerances)**



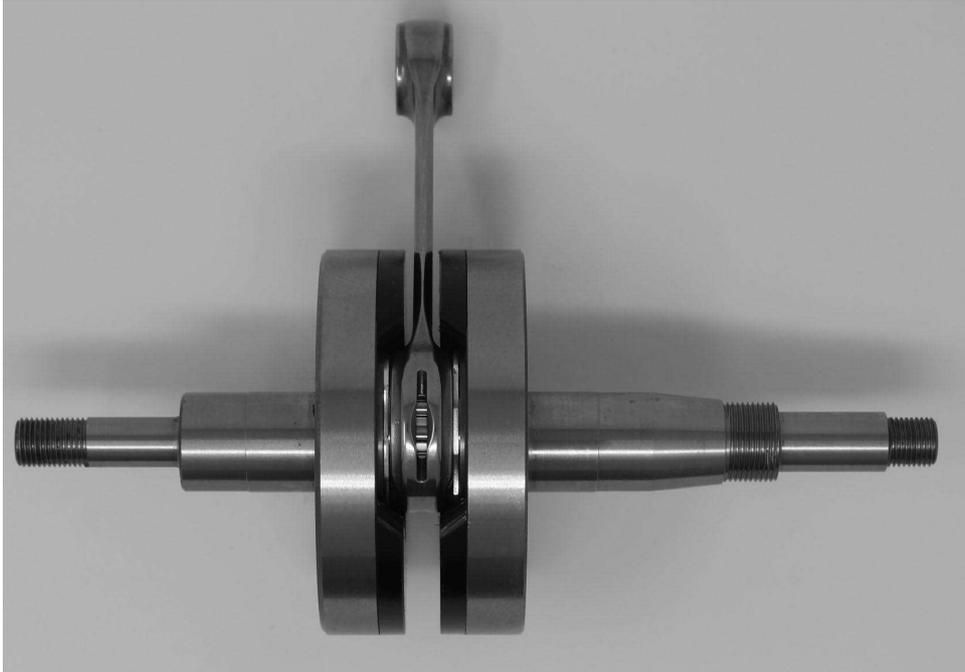
**Photos de demi-vilebrequins (une avec contrepoids en plastique, une sans) /  
Photos of crankshaft halves (one with plastic counterweight, one without)**



Homologation N°

041-EM-51

**Photo du vilebrequin et de la bielle /  
Photo of the crankshaft and conrod**



**Photo de la bielle droite / Photo of the conrod right**



**Photo de la bielle gauche / Photo of the conrod left**



Homologation N°

041-EM-51

Dessin du piston (dimensions principales sans tolérances et gabarit) /  
Drawing of the piston (main dimensions without tolerances and template)

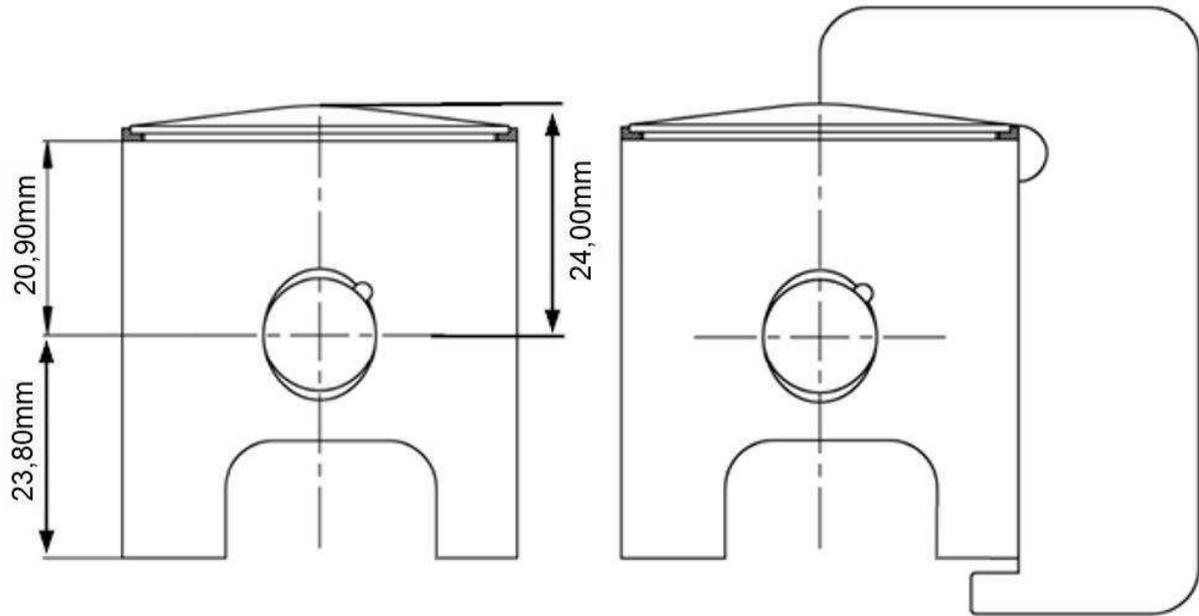


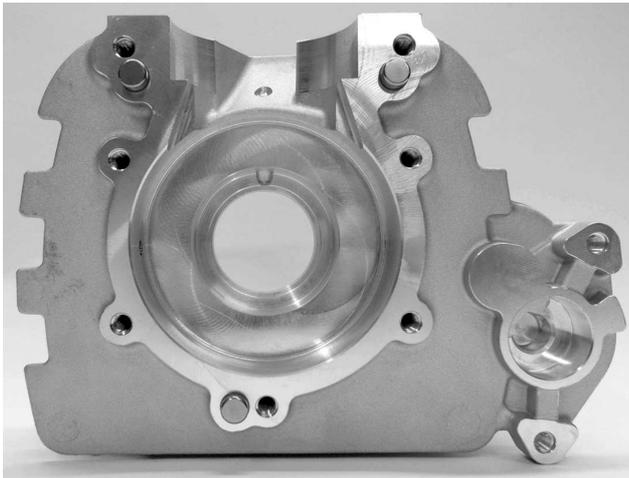
Photo du piston (de l'avant, de côté et d'en haut) / Photo of the piston (front, side and top)



Homologation N°

041-EM-51

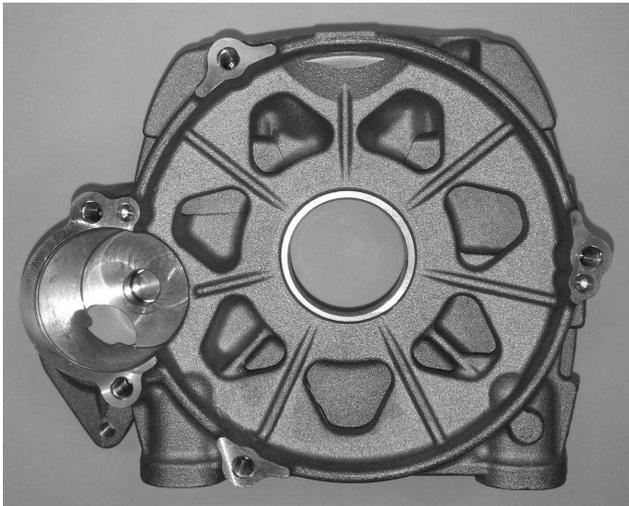
**Photo de l'intérieur du carter droit /  
Photo of the inside of the right crankcase**



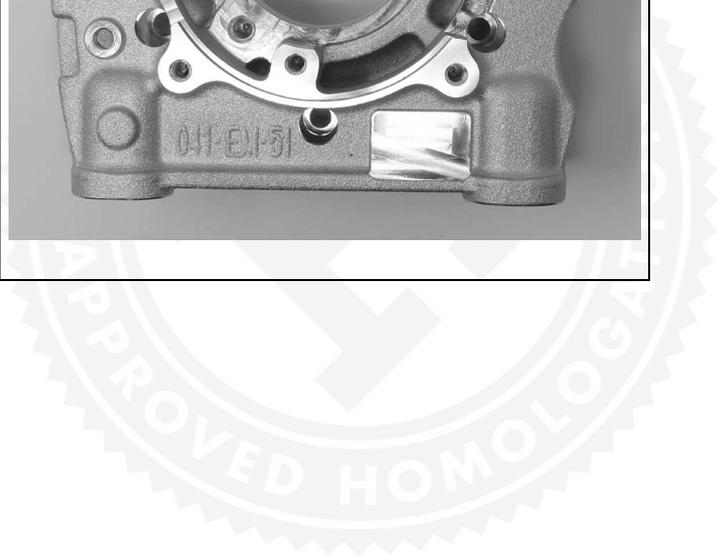
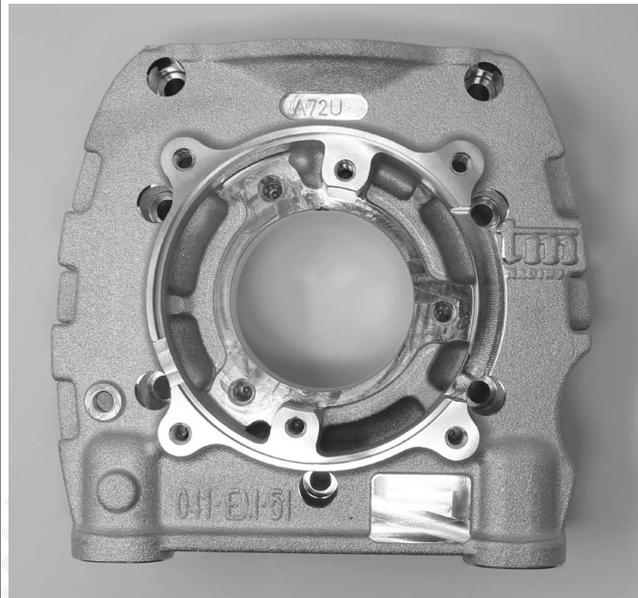
**Photo de l'intérieur du carter gauche /  
Photo of the inside of the left crankcase**



**Photo de l'extérieur du carter droit /  
Photo of the outside of the right crankcase**



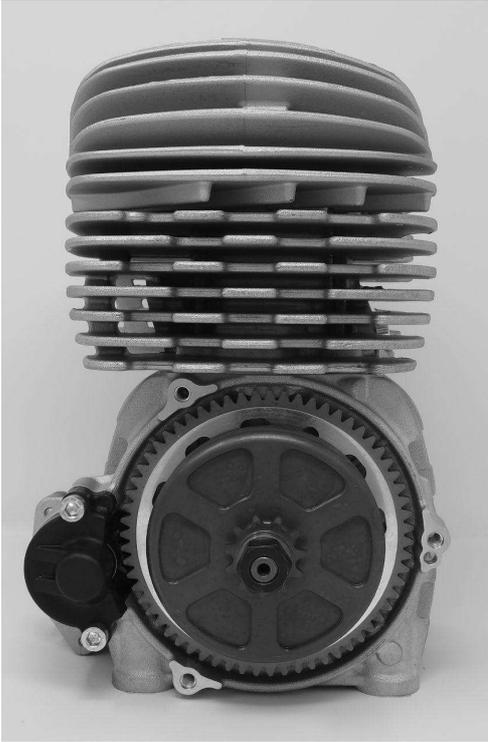
**Photo de l'extérieur du carter gauche /  
Photo of the outside of the left crankcase**



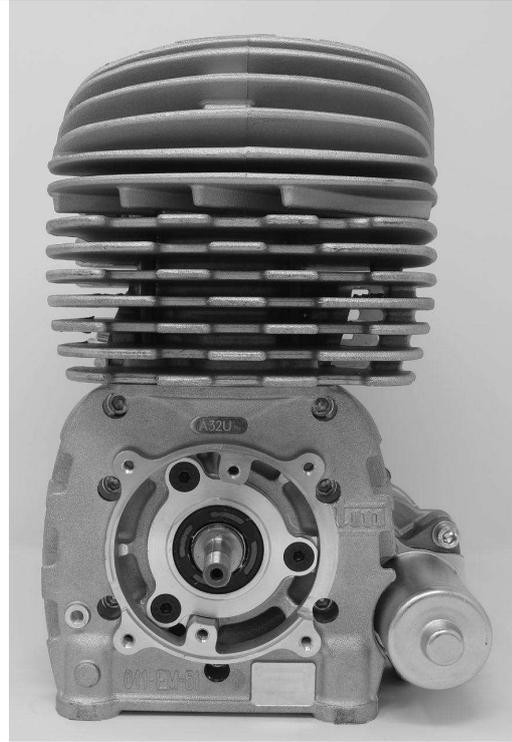
Homologation N°

041-EM-51

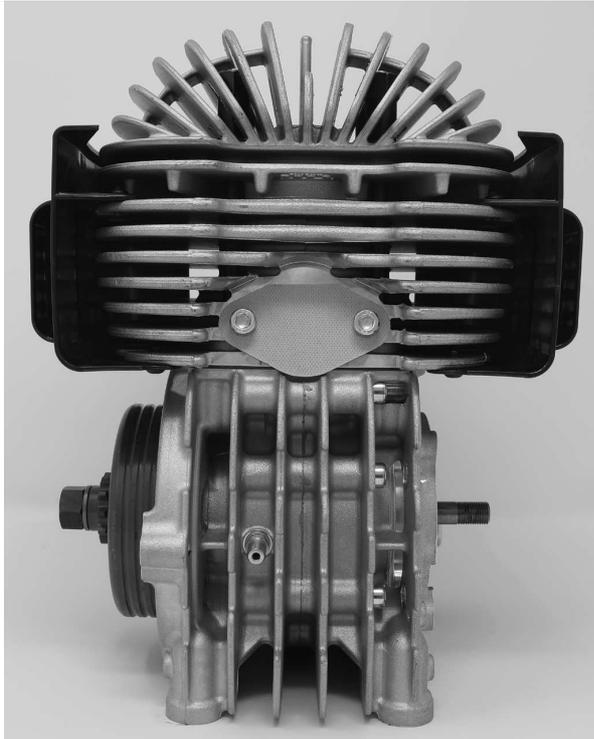
**Photo du moteur côté pignon /  
Photo of engine drive side**



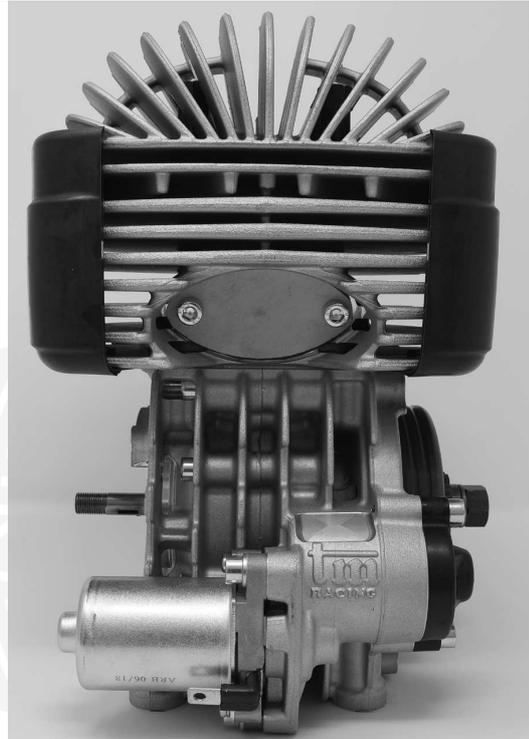
**Photo du moteur côté opposé /  
Photo of engine opposite side**



**Photo du moteur complet vu de l'avant /  
Photo of the complete engine front side**



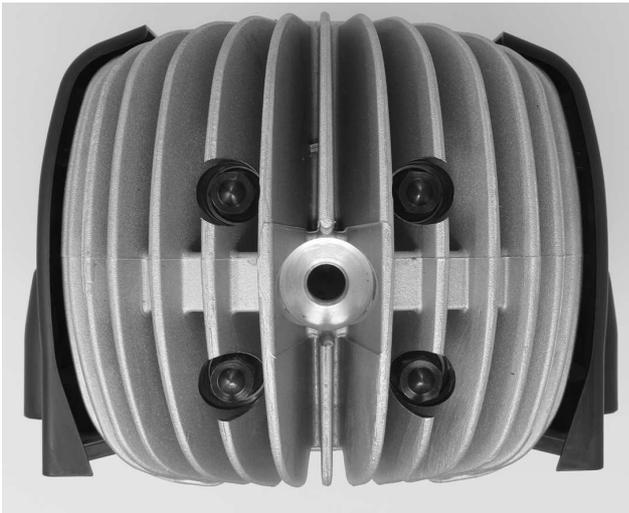
**Photo du moteur complet vu de l'arrière /  
Photo of the complete engine rear side**



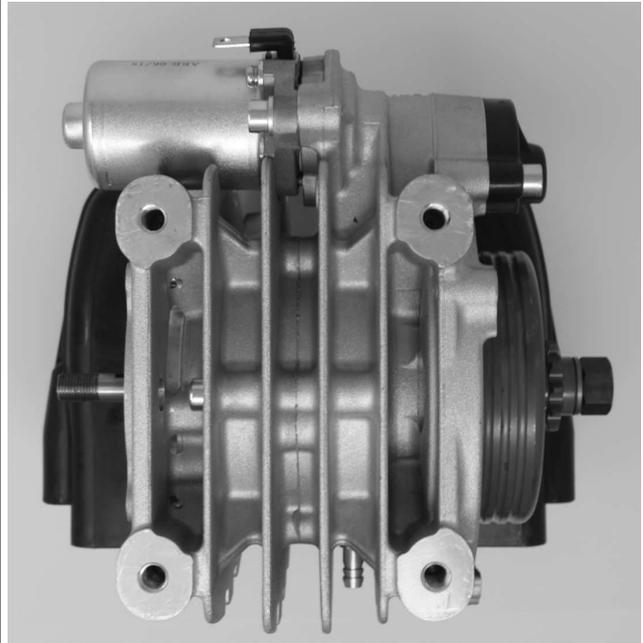
Homologation N°

041-EM-51

**Photo du moteur complet vu du haut /  
Photo of the complete engine taken from above**



**Photo du moteur complet vu du dessous /  
Photo of the complete engine taken from below**



**Photo des pièces plastiques du cylindre /  
Photo of the cylinder plastic parts**



**Photo du protège-chaîne et du couvercle d'allumage /  
Photo of the chain guard and ignition cover**



F

**Marquage des pièces principales / Main parts marking**

**Pour chaque pièce, photo d'ensemble avec le marquage et photo avec zoom sur le marquage /  
For each part, overall photo with marking and zoomed photo of marking**

1. Fonderies des carters droit et gauche
2. Cylindre
3. Culasse
4. Chemise en fonte
5. Demi-vilebrequins
6. Bielle
7. Piston

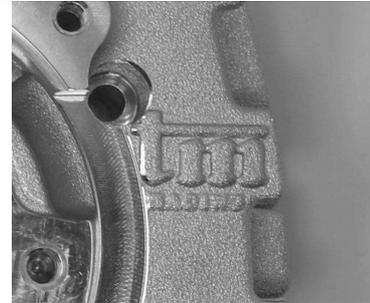
1. Castings of LH & RH crankcases
2. Cylinder
3. Cylinder head
4. Cast iron liner
5. Half-crankshafts
6. Conrod
7. Piston

**Pièces N° /  
Parts no.**

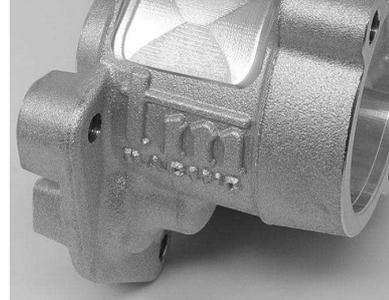
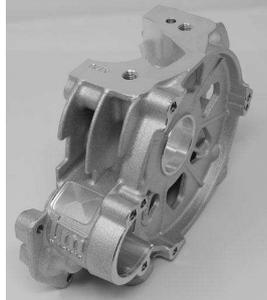
**Photo d'ensemble / Overall picture**

**Zoom**

1

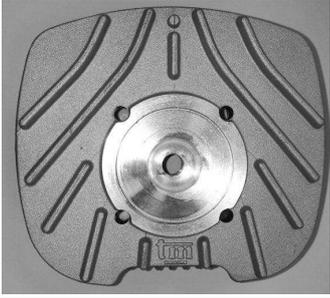
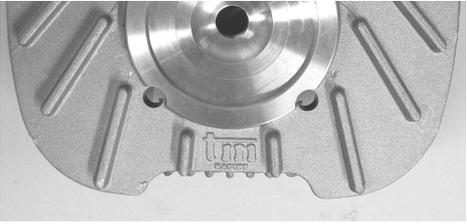
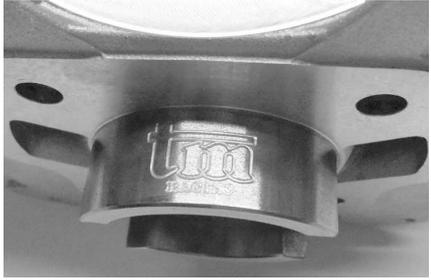


1



2



<p>3</p>		
<p>4</p>		
<p>5</p>		
<p>6</p>		
<p>7</p>	